

RIDE ^ RYTE™

BOOSTER SEAT

— 2 BOOSTERS IN 1 —

Owner's Manual

NB321/FB322



Detachable back for conversion to a No-Back booster

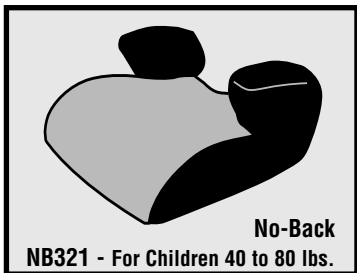

READ THIS MANUAL

Do not install this car seat until you read and understand the instructions in this manual.

Death or serious injury can result from not following manufactures instructions correctly.



SAFETY ANGEL

©2004 Ride Ryte™



Ready. Set. Grow!

General Safety



FAILURE TO FOLLOW THESE INSTRUCTIONS CAN RESULT IN A CHILD'S INJURY DURING A SUDDEN STOP OR CRASH.

If the Full-Back FB322 Booster is unbuckled to use as a No-Back Booster NB321 instructions **must** be followed **in booklet** not from FB322 instructions on seat bottom. A No-Back booster must be used **40-80lbs** in passenger vehicles and **30-80lbs** in school buses.

- **Read this manual completely before using the Ride Ryte™ Booster.**

Store the manual by placing it under the cover of Model NB321 bottom or on the back of Model FB322. Call **1-888-RIDE-RYTE**, for a manual to have us mail you one or download a new one @ www.safetyangel.com

- Proper fitting of this booster seat is required. Refer to this manual for the correct steps to follow.
- **Never leave the child alone in the car.**

INDEX	PAGE
General Safety	1
How To Use This Manual	2
Register Your Booster Seat	2
Correct Use of Your Ride Ryte™	3-4
Vehicle Use for Your Ride Ryte™	5-6
How to Unbuckle the FB322 (Full-Back) to a NB321 (No-Back) Booster	7
How to Adjust the FB322 (Full-Back)	8
How to Use with Vehicle Belt.	9
How to use with E-Z-ON™ Restraint System	10
Washing and Care Instructions	11
Troubleshooting Guide	12

How To Use This Manual

Read this entire manual before using your Ride Ryte™ Booster Seat.

WARNING!

**FAILURE TO FOLLOW INSTRUCTIONS MARKED WITH A WARNING!
MAY RESULT IN A CHILD'S SERIOUS INJURY OR DEATH.
ALL INSTRUCTIONS WITH A WARNING BOX MUST BE FOLLOWED EXACTLY.**

CAUTION

**FAILURE TO FOLLOW INSTRUCTIONS LABELED WITH A CAUTION, CAN RESULT
IN MINOR OR MODERATE INJURY OR CAUSE THE CHILD DISCOMFORT.**

NOTE:

This explains more detail to help you reach a better understanding of the use of your Ride Ryte™ Booster Seat.

If you have any questions about installations or use, call Safety Angel Inc. at **1-888-RIDE-RYTE** or email: **info@safetyangel.com**

REGISTER YOUR RIDE RYTE™ BOOSTER SEAT

Child restraints could be recalled for safety reasons.

You must register this restraint to be reached in a recall.

Use the registration card or send your name, address, and the restraint's model number and manufacturing date found on the label on the back of the seat bottom to:

SAFE START INC./SAFETY ANGEL INC.

P.O. Box 740151

Boyton Beach, FL 33474-0151

For recall information, call the National Highway Traffic Safety Auto Hotline at: **1-800-424-9393** or **202-366-0123** in the D.C. area.

**REPLACE THE BOOSTER IF IT HAS BEEN INVOLVED IN A CRASH OR
5 YEARS FROM THE DATE OF MANUFACTURE.**

Correct Use Of The Ride Ryte™ Booster

THIS SEAT MEETS ALL APPLICABLE FMVSS STANDARDS INCLUDING 213 AND IS CERTIFIED FOR USE IN MOTOR VEHICLES.

THIS SEAT IS NOT CERTIFIED FOR FAA USE ON AIRPLANES

Model FB322 Full-Back Booster is for...

children who weigh between **30 to 80** pounds, in **motor vehicles** and **school buses** who are **between 33 and 54** inches in height. Three point **lap and shoulder belts** or **lap-only belts with E-Z-ON safety restraints** can be used with this booster.

Full-Back
FB322 with
LAP & SHOULDER BELT



Full-Back
FB322 with
E-Z-ON™ Y HARNESS
WITH LAP ONLY BELT



Model NB321 No-Back Booster is for...

children in motor vehicles weighing, **40 to 80** pounds and who are **between 33 and 54** inches in height. Three point **lap and shoulder belts** or **lap-only belts with E-Z-ON safety restraints** can be used with this booster. Vehicle seat back must be higher than the child's eye level. Children weighing **30 to 80lbs.** and **between 33 and 54** inches in height can use this booster riding in school **buses** with an **E-Z-ON™ safety restraint system with a lap-only belt** with the child's eye level below the bus seat back.

No-Back
NB321 with
LAP & SHOULDER BELT



No-Back
NB321 with
E-Z-ON™ Y HARNESS
WITH LAP ONLY BELT



- **DO NOT** use this booster seat on vehicle seats that are equipped with seat belts that automatically surround the passenger. **Children in front seats with airbags must have the airbag turned off and the vehicle seat pulled back far from the airbag compartment.** Crash data shows that children are safer riding in the back seat.
- **DO NOT** use the Full-Back Booster unless it is attached with connecting straps and the seat is properly adjusted (see Page 8.)

Correct Use Of The Ride Ryte™ Booster Seats

(cont.)

- If any part of this seat becomes worn, frayed, infected or damaged, replace the seat. Destroy the entire restraint if it has been in use in a crash, even if damage is not obvious. Replace after crash or 5 years from the date of manufacture.
- A young child may unbuckle a shoulder/lap belt system so attention to **all** children in the car is needed. **Do not** leave a child alone in the car.
- Unrestrained cargo can damage the seat and others in a crash. Secure or remove dangerous cargo before driving.
- Protect all webbing from sharp corners and edges that may cut. **Do not** repair or modify **any** part of the Ride Ryte™ Booster.
- **Do not** use the Ride Ryte™ if the child's eye level is **above** the booster seat back (Full-Back) **Model FB322** or **vehicle** seat back or headrest when used as (No-Back) **Model NB321**.
- This booster seat may not be used in the home or boat and should be used only on Federally approved vehicle seats with FMVSS approved belts and hardware.
- Use this booster seat only on forward facing vehicle and school bus seats. Do not allow booster to block bus emergency exit areas.
- The Ride Ryte™ **must** be secured to the vehicle when not in use. A loose seat may cause harm in a crash. No-Back booster (NB321) can velcro under the seat for easy storage, after attaching self-adhesive **hook** velcro under the seat.
- **DO NOT** allow the child to buckle into the seat at any time, without a responsible adult helping.
- **This restraint is NOT certified for aircraft use.** Not FAA approved.
- **DO NOT** use this booster seat on vehicle seats that have a depth of less than 15 inches. No cushion or thick padding can be placed under seat, only thin, non-slip liners are allowed.
- **DO NOT** use this booster seat on vehicle seats that have seat backs that can be moved forward without first releasing a latch. (Unlocked seat backs are not safe to use with this seat.)

Ne

Vehicle Use Of The Ride Ryte™ Booster

Model # FB322 For children weighing 30 to 80 lbs.



CORRECT USE

USE IN FRONT PASSENGER SEATS
WHEN AIRBAG IS TURNED OFF!

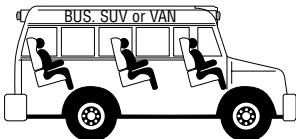

Use in school bus with E-Z-ON™ system only.



Use in complete forward facing seats only.



FB322 with
LAP & SHOULDER BELT



FB322 with
E-Z-ON™ Y HARNESS
WITH LAP ONLY BELT

The vehicle or bus belt should be adjusted snug; without slack. Follow the manufacturers' manuals for proper use when using E-Z-ON™ restraint systems in motor vehicles.

Crash data show children are safer when

properly restrained in rear seating positions in cars. Do not use a restraint blocking an emergency exit row on a school bus. Follow E-Z-ON™ instructions for proper use of Ride Ryte™ with their systems. Call E-Z-ON™ Products Inc. at **1-800 323-6598** if your instructions do not include Ride Ryte™ use. **The Ride Ryte™ Booster must be secured to the vehicle when not in use. A loose seat may cause harm in a crash.**



DO NOT USE

DO NOT USE IN FRONT PASSENGER SEATS
WHEN AIRBAG IS NOT TURNED OFF!



Do not use with a
lap belt ONLY.

Do not use on any vehicle seat which faces sideways or rearward. Do not use this restraint if the child's eye level is above the top of the booster seat back on the FB322.

WARNING

THIS BOOSTER SEAT IS NOT DESIGNED TO USE WITH A LAP BELT ALONE. USE WITH LAP BELT ALONE COULD RESULT IN SERIOUS INJURY OR DEATH TO THE CHILD.



Do not use without a 3 point shoulder/lap seat belt or without an E-Z-ON™ restraint system with seat belt.

Vehicle Use Of The Ride Ryte™ Booster

Model # NB321 For children weighing 40 to 80 lbs.



CORRECT USE

USE IN FRONT PASSENGER SEATS
WHEN AIRBAG IS TURNED OFF!

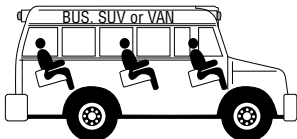

Use in school bus with a lap/shoulder belt or E-Z-ON™ system only.



Use in complete forward facing seats only.



NB321 with
LAP & SHOULDER BELT



NB321 with
E-Z-ON™ Y HARNESS
WITH LAP ONLY BELT

The vehicle seat belt should be adjusted snug; under the booster arms without belt slack. Follow the vehicle and restraint manual for proper use when using E-Z-ON™ restraint systems in motor vehicles.

Crash data show children are safer when properly restrained in rear seating positions in cars. Do not use a restraint blocking an emergency exit row on a school bus. Children from 30-80lbs in school buses can use this NB321 with E-Z-ON™ products. Follow E-Z-ON™ instructions for proper use of Ride Ryte™ with their systems. Call E-Z-ON™ Products Inc. at **1-800 323-6598** if your instructions do not include Ride Ryte™ use. **The Ride Ryte™ Booster must be secured to the vehicle when not in use. A loose seat may cause harm in a crash.**



DO NOT USE

DO NOT USE IN FRONT PASSENGER SEATS
WHEN AIRBAG IS NOT TURNED OFF!



Do not use with a
lap belt ONLY.



Do not use without a
3 point shoulder/lap seat
belt or without an E-Z-ON™
restraint system with seat belt.

WARNING

THIS BOOSTER SEAT IS NOT DESIGNED TO USE WITH A LAP BELT ALONE. USE WITH LAP BELT ALONE COULD RESULT IN SERIOUS INJURY OR DEATH TO THE CHILD.

How To Unbuckle The Full-Back Booster Model (FB322) To A No-Back Booster (NB321)

CAUTION

The seat is shipped pre-assembled (together). To unbuckle and use as a No-Back Booster (NB321) be sure **to use only when the child reaches 40lbs. in passenger cars vans or trucks.** School buses can use 30-80lbs. with E-Z-ON™ restraint systems.

1. Unzip Full-Back cover. Find buckle release, located under Full-Back cover
2. Press on release sides of buckle. Unbuckle.
3. Pull up velcro instructions on bottom seat.
4. Unthread connecting straps.

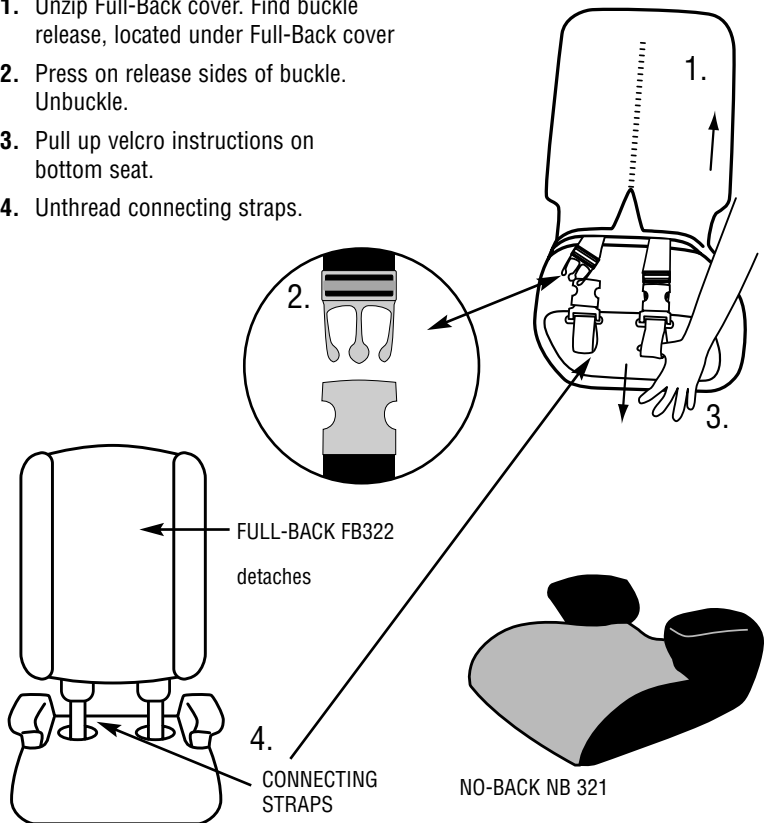

How To Adjust The Full-Back Booster Model (FB322)

NOTE:

The seat is shipped pre-assembled (together). To allow the booster fullback and seat bottom to fit securely, do the following:

- Rest the two **tabs** on the **full back** into the **seat slots** in the **seat bottom**
 - Allow for the **connecting straps** to run freely through the **slots** in the **seat bottom**.
- Flip the **seat bottom** and **full back** over and un-velcro the **instruction flap**. Rest the top of the **full back** on the floor. Be sure that the **tabs** rest in the **seat slots**.
 - Place your thumb through each **loop near the seat seat slots** and pull webbing for a bit of slack. Each **connecting strap** should be pulled fairly snug, allowing only slight movement for the **full back** to fit against the passenger seat.
 - Normal use and wear may allow the connecting straps to loosen. Pull webbing firmly in a straight line with thumb in loop to create a snug fit for the full back with seat bottom.

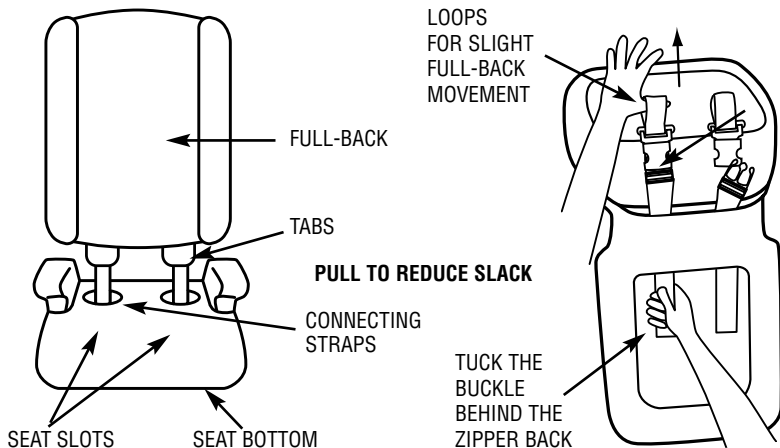

How To Use The Ride Ryte™ With Vehicle Lap And Shoulder Belt

USE WITH: ADULT 3- POINT lap/shoulder belts
FRONT **with Airbag Turned Off** and REAR SEAT POSITIONS



WARNING!

CHILDREN CAN MOVE A VEHICLE BELT UNDER THEIR ARM OR OUT OF CORRECT POSITION. THIS COULD CAUSE AN INJURY DURING A SUDDEN STOP OR CRASH. IF THE CHILD WILL NOT LEAVE THE BELT IN PLACE, DO NOT USE THE RIDE RYTE™ BOOSTER.

1. Place the RIDE RYTE™ BOOSTER on the correct vehicle seat. See pages 5-6. Be sure the booster has full contact (back and bottom) with the vehicle seat. **Use ONLY a good condition 3 point lap/shoulder belt.**
2. Place child with buttocks against seat back in the RIDE RYTE™ BOOSTER.
3. Place the shoulder/belt portion across the child's center chest. Route the shoulder belt over the outside of the arm rest. This will allow the belt to lay closer to the child's chest. See the diagram below.
4. Be sure the lap belt portion of the lap/shoulder belt is low and under the booster arms. Adjust the lap portion of the seat belt snugly around the child and booster, remove all twists and slack in the webbing. Allow the slack webbing to go back to where the webbing is stored. Buckle the belt and be sure it is secure.
5. If necessary, adjust the vehicle seat to improve the position of the shoulder belt on the child's chest.
6. The RIDE RYTE™ BOOSTER (Model FB322) is included with two belt guides. These are on both sides of the seat back. These loops are provided to guide the shoulder belt correctly across the child's chest for their size. Fit the correct belt guide and snap to close.
7. The shoulder strap seatbelt should **not** touch the neck area of the child.

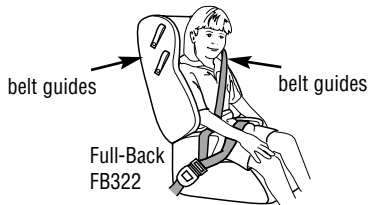
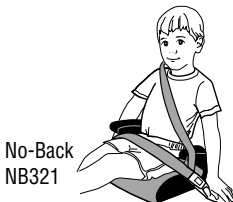

How To Use The Ride RYTE™ Booster With E-Z-ON™ Harness System

CAUTION

1. **Place the RIDE RYTE™ BOOSTER on the correct vehicle seat. Booster WEIGHT LIMITS VARY. See pages 5-6.**
Be sure the booster has full contact (back and bottom) with the vehicle seat. **Use ONLY an operative (well working) three point lap/shoulder belt or lap only belt. A three point belt needs a locking clip to use the lap belt portion only. Both belt portions must thread under the booster arms.**
Follow the locking clip directions for correct use with E-Z-ON™ instructions.
2. Place child with buttocks against seat back in the RIDE RYTE™ BOOSTER
3. Follow E-Z-ON™ instruction manual. Some system installations vary. A tether hook and hardware must be used correctly. Call E-Z-ON™ **1-800-323-6598** for instruction help if you have questions. **E-Z-ON™ Restraint Systems are to be used with the Ride RYTE™ Booster up to 80lbs.** Thread the lap belt through the loops on the harness correctly.
4. Be sure the lap belt portion is low and under the booster arms. Adjust the harness and vehicle seat belt snugly on the child and booster, remove all twists and slack in the webbing. Buckle the belt and be sure it is secure.
5. **BE SURE THE E-Z-ON™ HARNESS TETHER HOOK IS ATTACHED CORRECTLY.**

NOTE: Check to be sure the vehicle belt is not damaged or frayed and that the webbing can lock either at the latch plate or retractor, (where the webbing is stored.) Read your owner's manual for further information. Some seating positions because of narrow width or unequal belt anchors will not allow the Ride Ryte™ to fit correctly. Do not use unless the booster fits flat on vehicle seat. Do not put any cushion or thick padding under your Ride Ryte™ Booster. Only thin, non slip liners can be used under booster.



Washing & Care Instructions

To remove the covers, press on the release sides of both buckles located behind seatback cover. Unzip the cover from the top first.

To remove cover from the seat bottom, pull open the velcro label and pull cover from the rear pushing it forward over the arm rests.

To wash cover, wash by hand and use mild soap.

DO NOT BLEACH.

To replace covers after line drying:

Pull seat back cover over its wider part first, then stretch cover over the top of the Full-Back.

For the seat bottom:

Slip seat cover over the armrests first. Fit firmly then stretch cover over the seat. Zip up to close.

Refasten the buckles and follow instructions on page 8 on how to adjust the RIDE RYTE™ BOOSTER for use. (Model FB322)

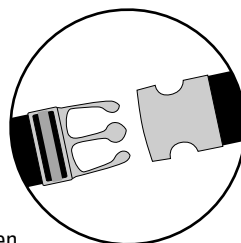

NOTE:

Remove Instruction Booklet from the back on Model FB322 and under seat on Model NB321 before washing and replace after refitting cover.

When seat is not in use handle with care. Do not put heavy weighted objects on seat. This may damage the arms of the booster so that they may not protect your child during a crash.

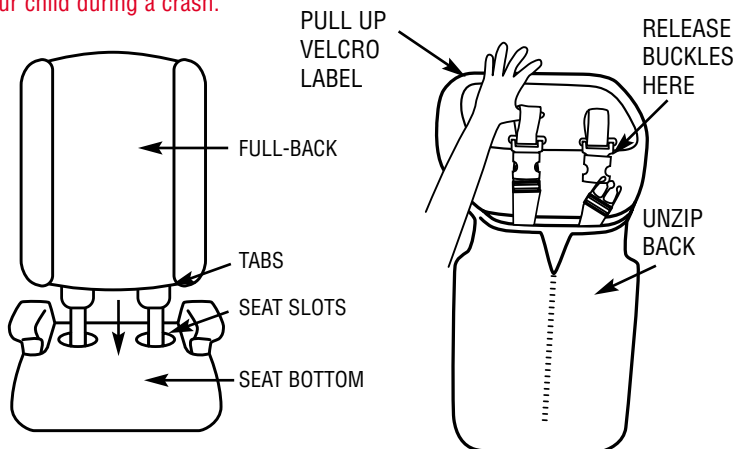

Troubleshooting Guide

PROBLEM: Booster seat wobbles, or cannot place booster firmly against vehicle seat.

SOLUTION: Move booster seat to another vehicle seating position that will allow the booster to sit flat on the vehicle seat. Check for and remove any loose objects which may be under booster seat. Check that the positioning tabs on the booster Full-Back are correctly placed into the slots in the base of the seat bottom.

PROBLEM: The shoulder belt portion of vehicle's lap/shoulder restraint rubs against child's neck or face.

SOLUTION: The 3-point lap/shoulder belt system should never pass over the child's neck or face. Re-adjust RIDE RYTE™ BOOSTER belt positioning loop (on Model FB322 only) as necessary to achieve proper fit following the instructions on page 9. In some instances, shoulder belt fit may be corrected by moving the vehicle's seat forward or backward (where adjustable) or sideways. Moving slightly towards the buckle may also help. If you cannot adjust the vehicle's shoulder belt properly using RIDE RYTE™ BOOSTER belt positioning loop guides or by moving the booster or vehicle seat, **DO NOT use the booster seat.**

PROBLEM: The child climbs out of the booster seat.

SOLUTION: No child restraint is escape proof. The vehicle's lap and shoulder belt should always remain in the correct position and stay buckled on the child correctly. Stress the importance of remaining in the booster seat to the child. If the child will not leave the shoulder portion of the vehicle belt in place, **DO NOT** use the RIDE RYTE BOOSTER™.

PROBLEM: Vehicle shoulder belt does not slide freely as child moves.

SOLUTION: Re-adjust belt positioning loop as necessary to allow free movement of the vehicle shoulder belt as the child moves. The shoulder belt should move forward with the child as he/she leans forward, and move backward as he/she returns to an upright sitting position, just as the belt system would on an adult. Check that the lap/shoulder belt is not twisted. Follow the instruction on page 9 to re-adjust the belt loop guide for proper fit.

NOTE:

If you are unable to properly adjust the seat as directed in this manual, or are having a problem not addressed in the Troubleshooting Guide, please call SAFETY ANGEL INC. toll free customer service at: 1-888 RIDE-RYTE. (1-888-743-3798)



SAFETY ANGEL

Psalm 91:9-11